

BSSE48-13

STAINLESS STEEL EXHAUST HOOD N.S.F. LISTED. CONFORMS TO NFPA96

Hood Constructed with continuous liquid-tight weld in conformance to IMC 2012 507.7.1.

Hood material: 18 Gauge 430 STAINLESS STEEL (#3 polish) where exposed.

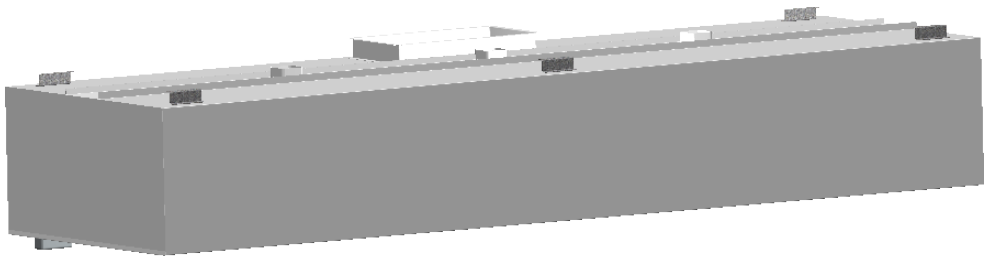
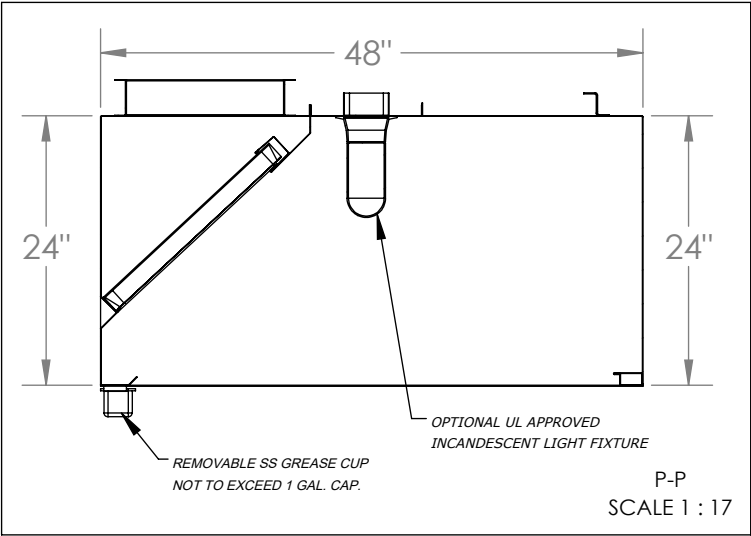
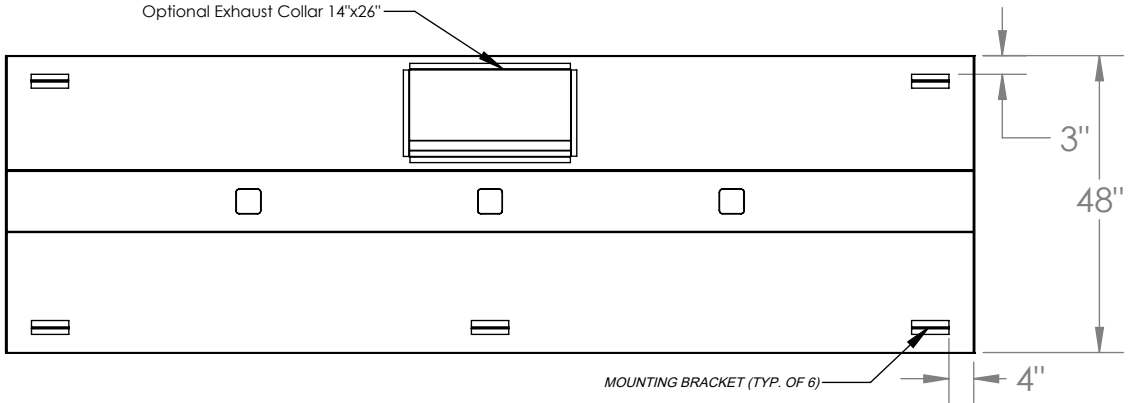
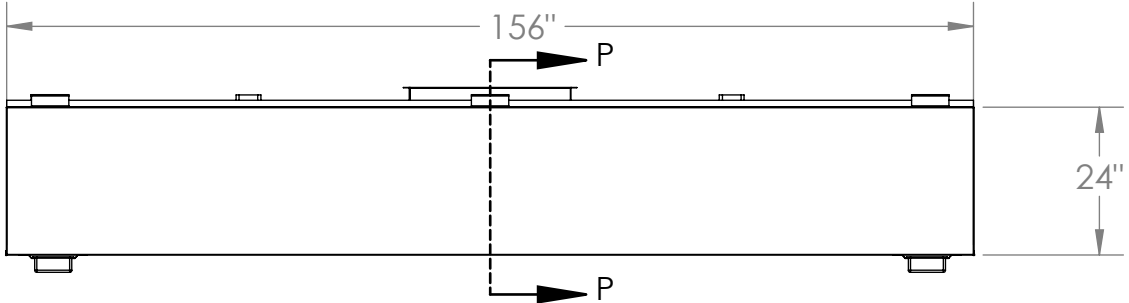

MODEL INFORMATION						
TYPE	DIMENSIONS			CFM SPECS		WEIGHT
	LENGTH	WIDTH	HEIGHT	EXHAUST PLENUM	SUPPLY PLENUM	
1	156"	48"	24"	3928 @ 0.5 ESP	3142 @ 0.12 ESP	346 lbs

OBS.: Installing contractor have the responsibility to ensure hood clearance from limited-combustible and combustible materials is compliant with local code requirements.

STANDARD COMPONENTS					
MOUNTING BRACKET 12-GAUGE GALVANIZED	Grease Drain	Grease Cup Stainless Steel NSF	Grease Filter Stainless Steel UL 1046		
QTY	QTY	QTY	QTY	Length	Height
6	2	2	0	16"	20"
			4	20"	20"
			3	25"	20"

SUGGESTED COMPONENTS					
Exhaust Collar		Standoff	Incandescent Light Fixture	Shipping Crate	
16-Gauge Cold Rolled Build				Dimensions (in) and Weight (lb)	Length:
QTY	Size	<input type="checkbox"/> NONE <input type="checkbox"/> 3" <input type="checkbox"/>	UL Listed (Included Component)	Width:	52"
				Height:	32"
1	14" x 26"		QTY	Weight:	476 lbs

 PO BOX 47607 - ATLANTA, GA 30360 PHONE: 770.936.0770 - www.superiorhoods.com		PROJECT BSSE48-13			
		TITLE BSSE48 HOOD MODEL STANDARD SPEC SHEET			
APPROVED	SIZE B	CODE	DWG NO		REV 01
CHECKED	DRAWN		PRODUCTION	2023	SCALE: 1:31
WEIGHT: 346 lbs		SHEET: 1/1			