

BSSM48 ETL-13

STAINLESS STEEL EXHAUST HOOD N.S.F. LISTED. CONFORMS TO NFPA96

Hood Constructed with continuous liquid-tight weld in conformance to IMC 2012 507.7.1.

Hood material: 18 Gauge 430 STAINLESS STEEL (#3 polish) where exposed.

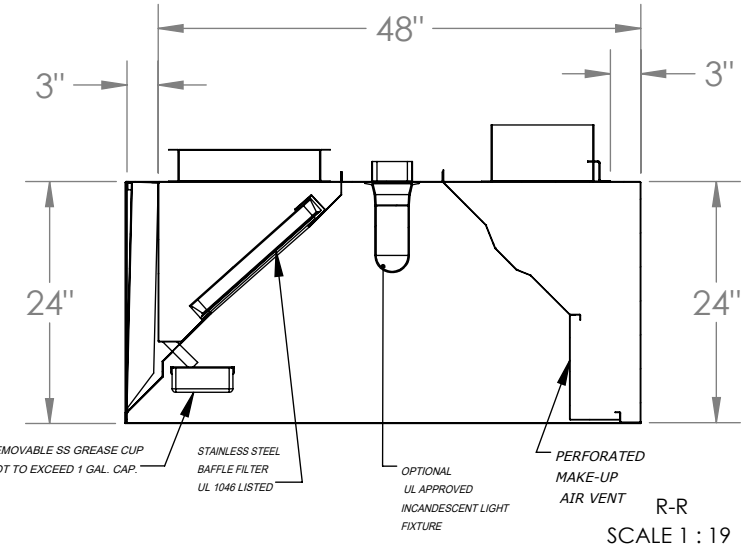
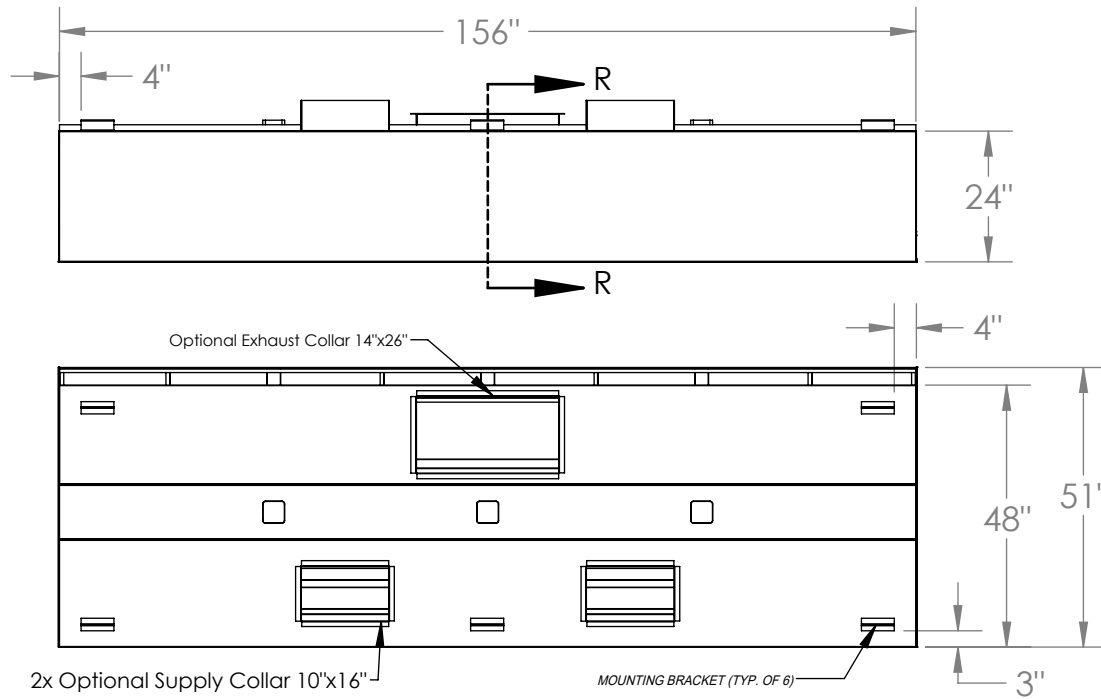

MODEL INFORMATION							
TYPE	DIMENSIONS			CFM SPECS		WEIGHT	
	LENGTH	WIDTH	HEIGHT	EXHAUST PLENUM	SUPPLY PLENUM ¹	445 lbs	
1	156"	51"	24"	3928 @ 0.5 ESP	3142 @ 0.12 ESP		

OBS.:
Installing contractor have the responsibility to ensure hood clearance from limited-combustible and combustible materials is compliant with local code requirements.

¹ Sold Separately

STANDARD COMPONENTS INCLUDED							
MOUNTING BRACKET 12-GAUGE GALVANIZED	Incandescent Light Fixture	Standoff	Grease Drain	Grease Cup Stainless Steel NSF	Grease Filter Stainless Steel UL 1046		
QTY	UL Listed (Included Component)	3" back standoff included	QTY	QTY	QTY	Length	Height
6	QTY		2	2	0	16"	16"
	3		2	2	4	20"	16"
				3	25"	16"	

SUGGESTED COMPONENTS							
Exhaust Collar		Supply Collar (Built-in Fire Damper)		Side Standoff	Shipping Crate		
16-Gauge Cold Rolled Build		16-Gauge Cold Rolled Build			Dimensions (in) and Weight (lb)		
QTY	Size	QTY	Size	<input type="checkbox"/> NONE <input type="checkbox"/> 3" <input type="checkbox"/> _____	Length:	160"	
					Width:	55"	
					Height:	32"	
1	14" x 26"	2	10"x16"		Weight:	575 lbs	

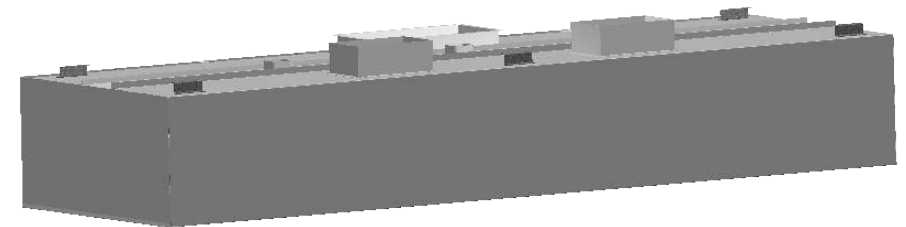

 PO BOX 47607 - ATLANTA, GA 30360 PHONE: 770.936.0770 - www.superiorhoods.com		PROJECT BSSM48 ETL-13			
		TITLE BSSM48 ETL HOOD MODEL STANDARD SPEC SHEET			
APPROVED	SIZE B	CODE	DWG NO		REV 01
CHECKED	DRAWN		PRODUCTION	2023	SCALE: 1:35
WEIGHT: 445 lbs		SHEET: 1/1			