

BSSM48 ETL-14

STAINLESS STEEL EXHAUST HOOD N.S.F. LISTED. CONFORMS TO NFPA96

Hood Constructed with continuous liquid-tight weld in conformance to IMC 2012 507.7.1.

Hood material: 18 Gauge 430 STAINLESS STEEL (#3 polish) where exposed.

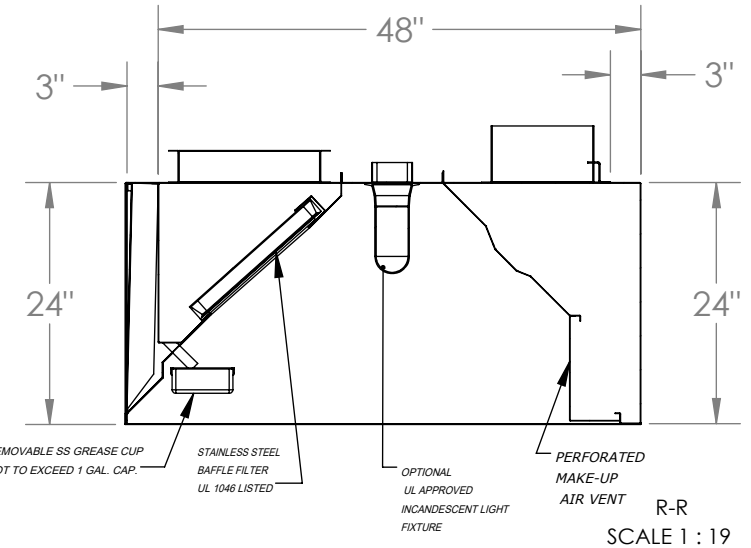
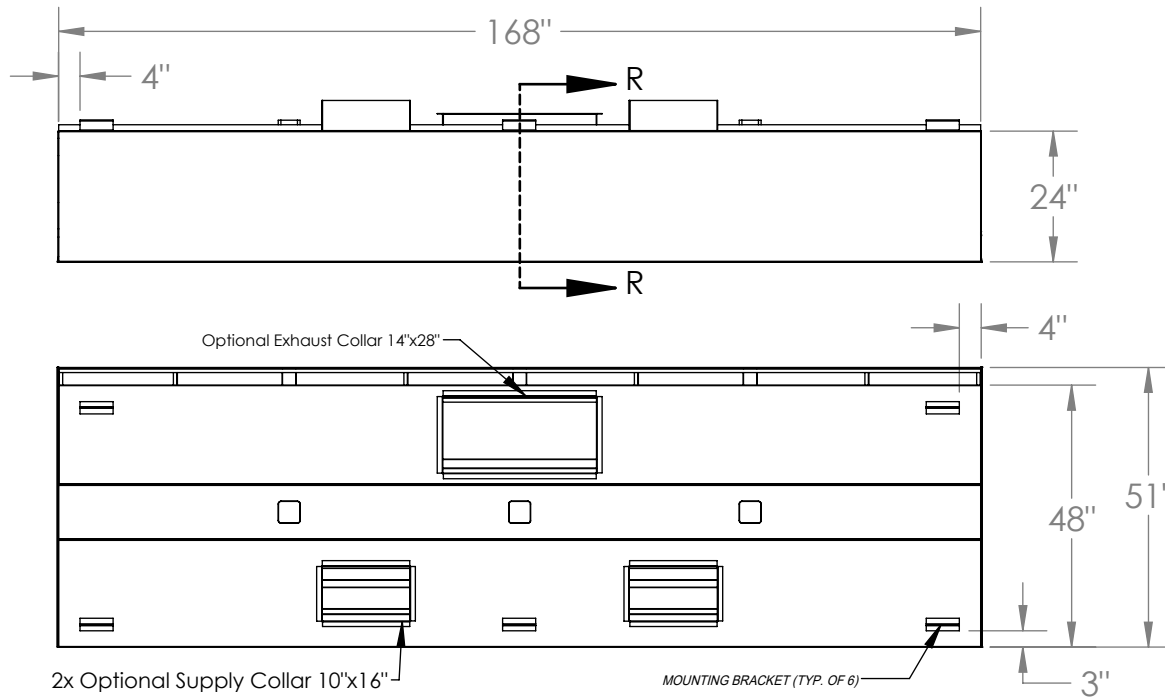

MODEL INFORMATION

TYPE	DIMENSIONS			CFM SPECS		WEIGHT
	LENGTH	WIDTH	HEIGHT	EXHAUST PLENUM	SUPPLY PLENUM ¹	
1	168"	51"	24"	4230 @ 0.5 ESP	3384 @ 0.12 ESP	475 lbs

OBS.:
Installing contractor have the responsibility to ensure hood clearance from limited-combustible and combustible materials is compliant with local code requirements.

¹ Sold Separately

STANDARD COMPONENTS INCLUDED

MOUNTING BRACKET 12-GAUGE GALVANIZED	Incandescent Light Fixture	Standoff	Grease Drain	Grease Cup Stainless Steel NSF	Grease Filter Stainless Steel UL 1046		
QTY	UL Listed (Included Component)	3" back standoff included	QTY	QTY	QTY	Length	Height
6	QTY		2	2	0	16"	16"
	3		2	2	2	20"	16"
		5	2	2	5	25"	16"

SUGGESTED COMPONENTS

Exhaust Collar		Supply Collar (Built-in Fire Damper)		Side Standoff	Shipping Crate	
16-Gauge Cold Rolled Build		16-Gauge Cold Rolled Build			Dimensions (in) and Weight (lb)	
QTY	Size	QTY	Size	<input type="checkbox"/> NONE <input type="checkbox"/> 3" <input type="checkbox"/> _____	Length:	172"
					Width:	55"
					Height:	32"
1	14" x 28"	2	10"x16"		Weight:	615 lbs

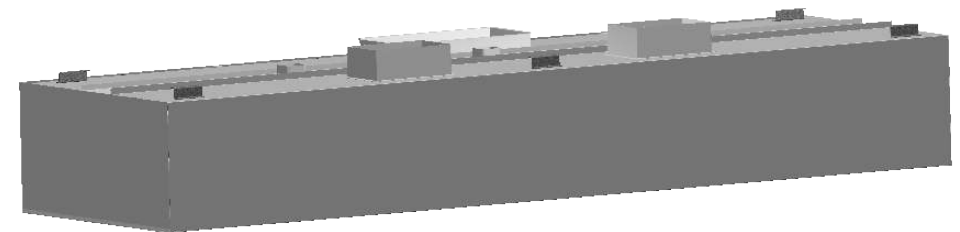

PO BOX 47607 - ATLANTA, GA 30360
PHONE: 770.936.0770 - www.superiorhoods.com

PROJECT

BSSM48 ETL-14

TITLE

BSSM48 ETL HOOD MODEL STANDARD
SPEC SHEET

APPROVED

SIZE
B

CODE

DWG NO

REV
01

CHECKED

DRAWN

PRODUCTION

2023

SCALE: 1:35

WEIGHT: 475 lbs

SHEET: 1/1