

BSSM48 ETL-8

STAINLESS STEEL EXHAUST HOOD N.S.F. LISTED. CONFORMS TO NFPA96

Hood Constructed with continuous liquid-tight weld in conformance to IMC 2012 507.7.1.

Hood material: 18 Gauge 430 STAINLESS STEEL (#3 polish) where exposed.

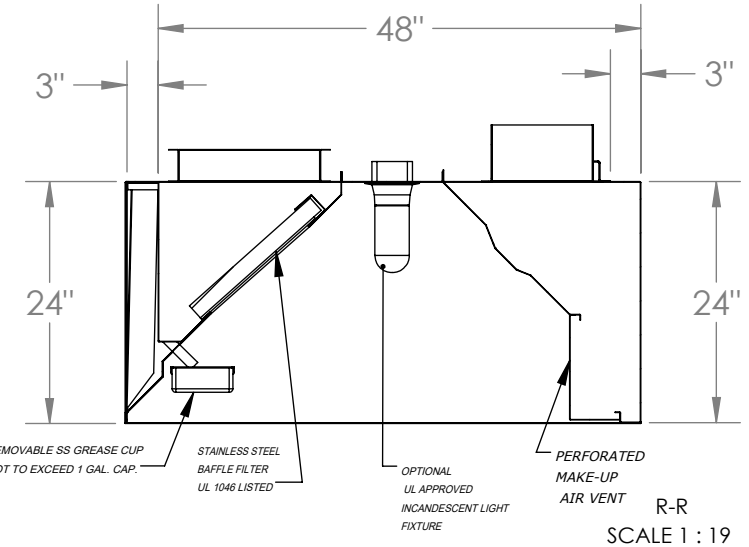
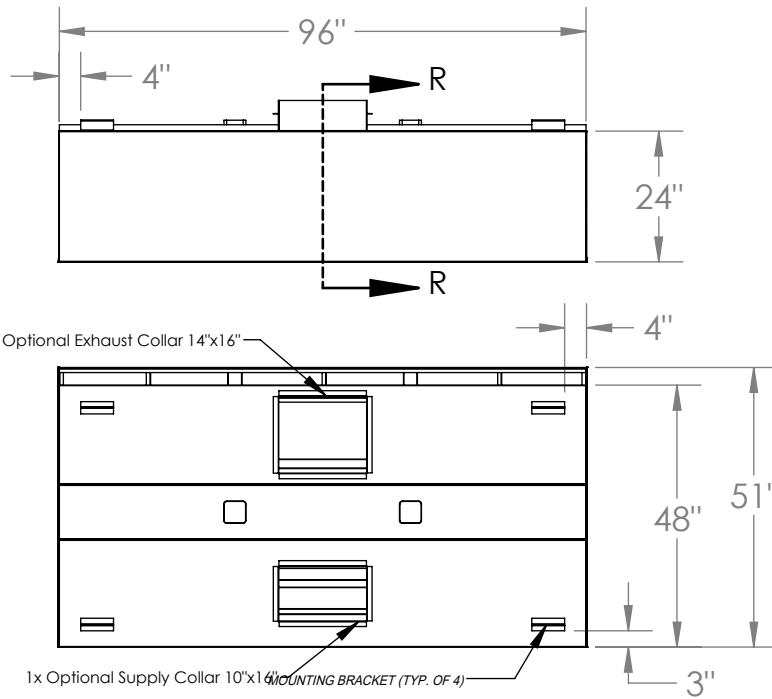

MODEL INFORMATION						
TYPE	DIMENSIONS			CFM SPECS		WEIGHT
	LENGTH	WIDTH	HEIGHT	EXHAUST PLENUM	SUPPLY PLENUM ¹	
1	96"	51"	24"	2417 @ 0.5 ESP	1933 @ 0.12 ESP	292 lbs

OBS.:
Installing contractor have the responsibility to ensure hood clearance from limited-combustible and combustible materials is compliant with local code requirements.

¹ Sold Separately

STANDARD COMPONENTS INCLUDED							
MOUNTING BRACKET 12-GAUGE GALVANIZED	Incandescent Light Fixture	Standoff	Grease Drain	Grease Cup Stainless Steel NSF	Grease Filter Stainless Steel UL 1046		
QTY	UL Listed (Included Component)	3" back standoff included	QTY	QTY	QTY	Length	Height
4	QTY		1	1	0	16"	16"
	2				1	20"	16"
					3	25"	16"

SUGGESTED COMPONENTS						
Exhaust Collar		Supply Collar (Built-in Fire Damper)		Side Standoff	Shipping Crate	
16-Gauge Cold Rolled Build		16-Gauge Cold Rolled Build			Dimensions (in) and Weight (lb)	
QTY	Size	QTY	Size	<input type="checkbox"/> NONE <input type="checkbox"/> 3" <input type="checkbox"/> _____	Length:	100"
					Width:	55"
					Height:	32"
1	14" x 16"	1	10"x16"		Weight:	372 lbs

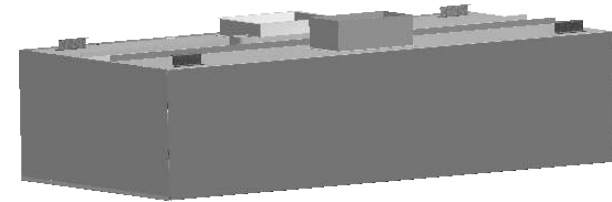

 PO BOX 47607 - ATLANTA, GA 30360 PHONE: 770.936.0770 - www.superiorhoods.com		PROJECT BSSM48 ETL-8			
		TITLE BSSM48 ETL HOOD MODEL STANDARD SPEC SHEET			
APPROVED	SIZE B	CODE	DWG NO	REV 01	
CHECKED					
DRAWN	PRODUCTION	2023	SCALE: 1:35	WEIGHT: 292 lbs	
				SHEET: 1/1	