

CSS30-12

STAINLESS STEEL EXHAUST HOOD N.S.F. LISTED. CONFORMS TO NFPA96

Hood Constructed with continuous liquid-tight weld in conformance to IMC 2012 507.7.1.

Hood material: 18 Gauge 430 STAINLESS STEEL (#3 polish) where exposed.

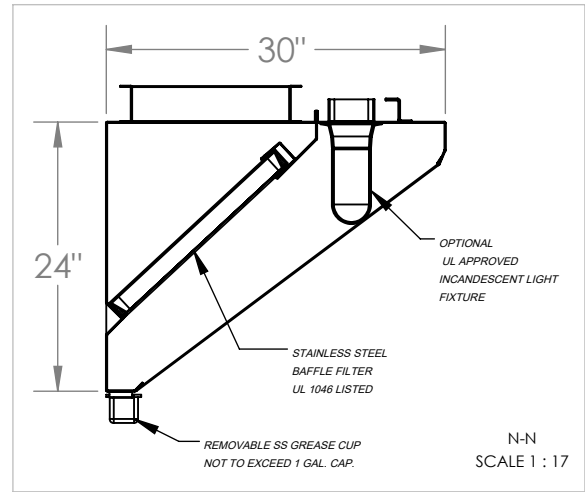



MODEL INFORMATION						
TYPE	DIMENSIONS			CFM SPECS		WEIGHT
	LENGTH	WIDTH	HEIGHT	EXHAUST PLENUM	SUPPLY PLENUM	
1	144"	30"	24"	3000 @ 0.5 ESP	N/A	217 lbs

OBS.: Installing contractor have the responsibility to ensure hood clearance from limited-combustible and combustible materials is compliant with local code requirements.

STANDARD COMPONENTS					
MOUNTING BRACKET 12-GAUGE GALVANIZED	Grease Drain	Grease Cup Stainless Steel NSF	Grease Filter Stainless Steel UL 1046		
QTY	QTY	QTY	QTY	Length	Height
6	2	2	0	16"	20"
			1	20"	20"
			5	25"	20"

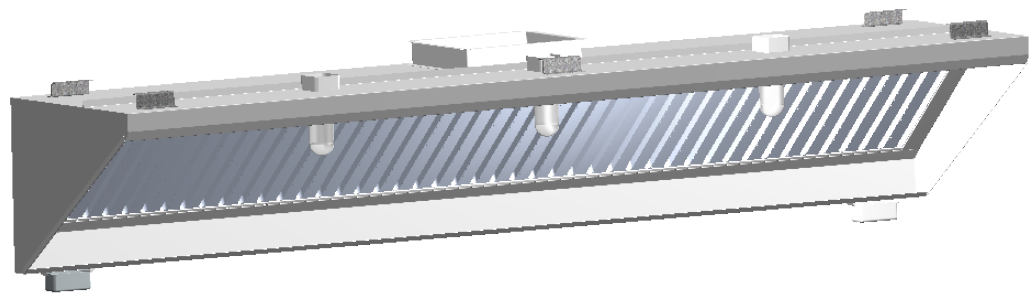
SUGGESTED COMPONENTS						
Exhaust Collar		Supply Collar		Incandescent Light Fixture	Shipping Crate	
					Dimensions (in) and Weight (lb)	
16-Gauge Cold Rolled Build		N/A		UL Listed (Included Component)	Length:	148"
					Width:	34"
					Height:	32"
QTY	Size	QTY	SIZE	QTY	Weight:	337 lbs
1	14" x 18.25"	N/A	N/A	3		



 PO BOX 47607 - ATLANTA, GA 30360 PHONE: 770.936.0770 - www.superiorhoods.com	PROJECT		CSS30-12		
	TITLE				
APPROVED	SIZE B	CODE	DWG NO		REV 01
CHECKED	DRAWN		PRODUCTION	2023	SCALE: 1:26
WEIGHT: 217 lbs			SHEET: 1/1		