

VSSD48-16

STAINLESS STEEL EXHAUST HOOD N.S.F. LISTED. CONFORMS TO NFPA96

Hood Constructed with continuous liquid-tight weld in conformance to IMC 2012 507.7.1.

Hood material: 18 Gauge 430 STAINLESS STEEL (#3 polish) where exposed.

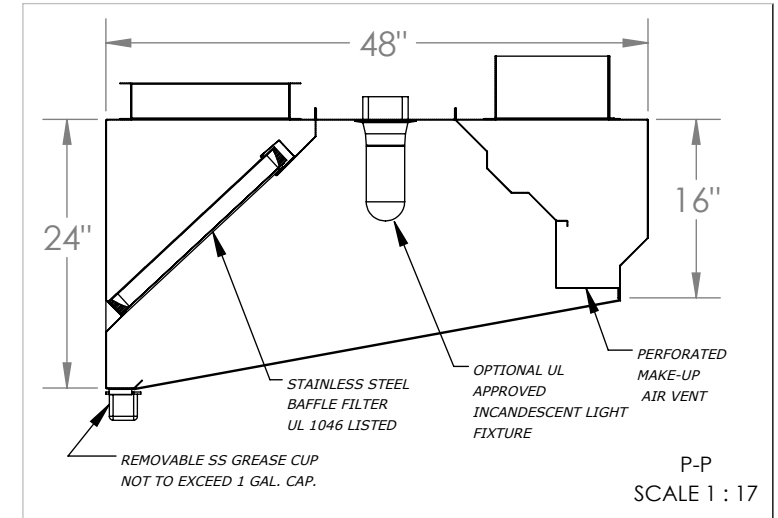
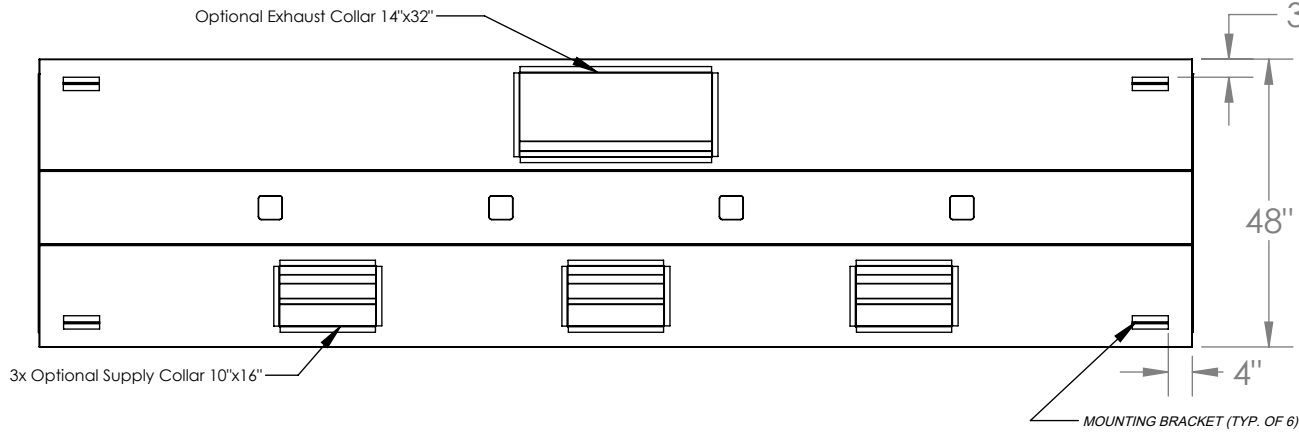
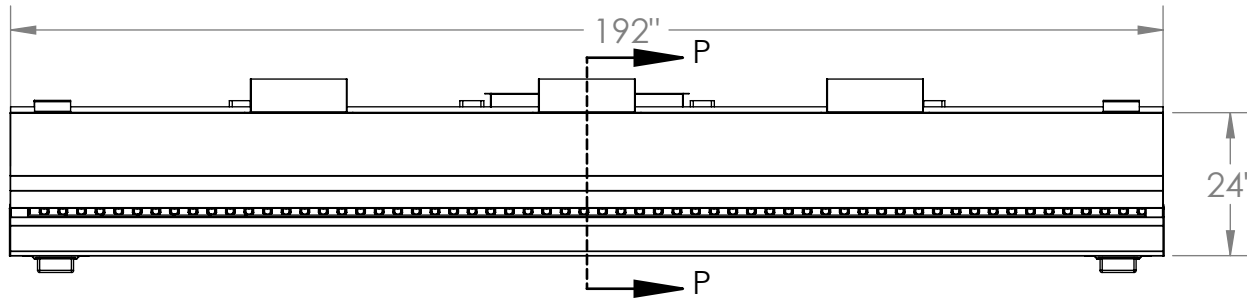

P-P
SCALE 1 : 17

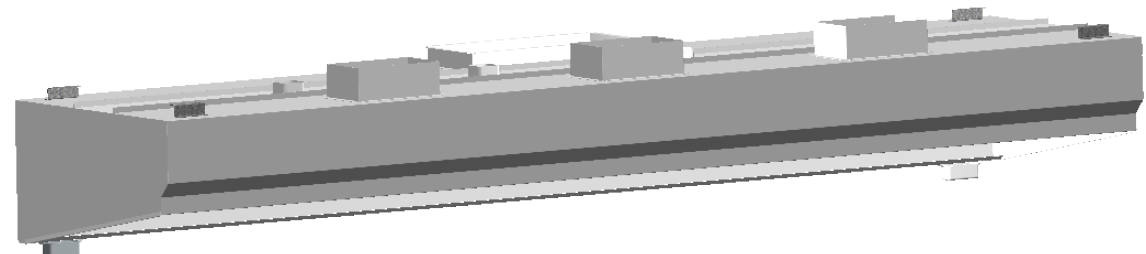

MODEL INFORMATION

| TYPE | DIMENSIONS | | | CFM SPECS | | WEIGHT |
|------|------------|-------|--------|----------------|-----------------|---------|
| | LENGTH | WIDTH | HEIGHT | EXHAUST PLENUM | SUPPLY PLENUM | |
| 1 | 192" | 48" | 24" | 4835 @ 0.5 ESP | 3867 @ 0.12 ESP | 450 lbs |

OBS.: Installing contractor have the responsibility to ensure hood clearance from limited-combustible and combustible materials is compliant with local code requirements.

STANDARD COMPONENTS

| MOUNTING BRACKET 12-GAUGE GALVANIZED | Grease Drain | Grease Cup Stainless Steel NSF | Grease Filter Stainless Steel UL 1046 | | |
|---|-----------------|-----------------------------------|---|--------|--------|
| QTY | QTY | QTY | QTY | Length | Height |
| 6 | 2 | 2 | 0 | 16" | 20" |
| | | | 1 | 20" | 20" |
| | | | 7 | 25" | 20" |

SUGGESTED COMPONENTS

| Exhaust Collar | Supply Collar (Built-in Fire Damper) | | Standoff | Incandescent Light Fixture | Shipping Crate | | |
|----------------|---|-------------------------------|-----------|--|--------------------------------------|---------|--------|
| | 16-Gauge Cold Rolled Build | 16-Gauge Cold Rolled Build | | | Dimensions (in) and Weight (lb) | | |
| QTY | Size | QTY | Size | <input type="checkbox"/> NONE <input type="checkbox"/> 3" <input type="checkbox"/> _____ | UL Listed (Included Component) | Length: | 196" |
| 1 | 14" x 32" | 3 | 10" x 16" | | | QTY | Width: |
| | | | | | Height: | 32" | |
| | | | | | Weight: | 610 lbs | |



PO BOX 47607 - ATLANTA, GA 30360
PHONE: 770.936.0770 - www.superiorhoods.com

| | | | | | |
|----------|------------|-------------------------------------|-------------|-----------------|------------|
| PROJECT | | VSSD48-16 | | | |
| TITLE | | VSSD HOOD MODEL STANDARD SPEC SHEET | | | |
| APPROVED | SIZE B | CODE | DWG NO | | REV 01 |
| CHECKED | | | | | |
| DRAWN | PRODUCTION | 2023 | SCALE: 1:32 | WEIGHT: 450 lbs | SHEET: 1/1 |